

SEAT HEATERS

INSTALLATION INSTRUCTIONS

RAV 4

Model year: 05 / 2000

Vehicle Code: **A2**L-A****W

Part number: PZ455-X0310-00

Weight: 0.45 kg

Installation time: + 20 mins
to leather
installation

LHD

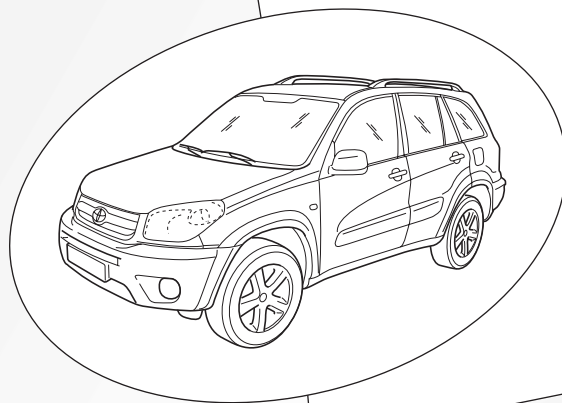

GB

- Expert Fitment Required.
- Disconnect the battery earth cable.
- Install parts as shown on illustrations.
- Re-connect battery.
- Re-fit panels, ensure that the wiring harness and other components are neatly and securely located.

D

- Montage durch Fachwerkstatt erforderlich.
- Massekabel von Batterie abklemmen.
- Teile gemäß Abbildung montieren.
- Batterie wieder anschließen.
- Paneele wieder anbringen; achten Sie darauf, daß der Kabelbaum und andere Teile ordnungsgemäß und genau positioniert sind.

E

- Montaje sólo por el concesionario.
- Desconectar el cable de masa de la batería.
- Montar las piezas tal como se indica en las figuras.
- Vuelva a conectar la batería.
- Volver a colocar los paneles; preste atención a que el mazo del cable y las demás piezas tengan la posición correcta y precisa.

F

- Montage par spécialiste nécessaire.
- Débrancher le câble de masse de la batterie.
- Monter les pièces selon les figures.
- Reconnecter la batterie.
- Remettre le panneau; veillez à ce que le faisceau et les autres pièces soient positionnés correctement et avec la précision requise.

I

- E' necessario in officina specializzata.
- Staccare il cavo di massa dalla batteria.
- Montare le parti secondo quanto rilevabile delle illustrazioni.
- Riconnettere la batteria.
- Rimettere in posizione i pannelli; far ben attenzione che il fascio di cavi e le altre parti siano state posizionate con esattezza e nella dovuta maniera.

P

- Especialista em montagem requerido.
- Separe o cabo de terra do acumulador.
- Monte as partes conforme ilustrado.
- Recolocar a bateria.
- Tomar a colocar os painéis; verificar se a árvore de cabos e outras peças estão na posição exacta e prescrita.

NL

- Montage door vakman nodig.
- Massakabel van accu losmaken.
- Delen overeenkomstig afbeelding monteren.
- Accu weer aansluiten.
- Panelen weer monteren; let erop, dat de kabelboom en andere delen correct en netjes gepositioneerd worden.

DK

- Montage ved professionelt værksted påkrævet.
- Stelkabel fjernes fra batteri.
- Dele skal monteres i henhold til illustrationer.
- Tilslut batteri igen.
- Paneler fastgøres igen; vær opmærksom på, at kabelsamlingen og andre dele placeres korrekt og præcist.

N

- Nødvendig med montering fra fagverksted.
- Klem jordkabelen av batteriet.
- Monter alle deler i henhold til illustrasjonene.
- Tilkobl batteriet igjen.
- Monter panelene igjen, og pass på at kabelbunten og andre deler er anbrakt ordentlig og på riktig sted.

S

- Verkstadsmontage erfordras.
- Lossa stomkabeln från batteriet.
- Montera detaljerna enligt figurerna.
- Anslut batteriet igen.
- Sätt tillbaka panelerna igen; kontrollera noga att ledningsmattan och andra detaljer ligger på rätt plats.

FIN

- Asennus tarpeen merkkikorjaamossa.
- Erotta maadoitusjohto akusta.
- Asenna osat kuvien mukaan.
- Kytke akku takaisin.
- Aseta paneelit paikalleen; tarkista, että kaapelointi ja muut osat ovat asianmukaisesti ja tarkalleen paikoillaan.

CZ

- Montáž ve specializované dílně nutná.
- Odpojte zemnicí kabel od baterie.
- Montujte části podle vyobrazení.
- Opět připojit baterii.
- Opět připevněte panely; dbejte na to, aby svazek kabelů a ostatní části byly uloženy na správném místě.

H

- A szereléshez szakműhely kell.
- Húzza le az akkumulátor testkábeljét.
- Az alkatrészeket az ábrák szerint szerelje be.
- Ismét csatlakoztassa az akkumulátort.
- Szerelje vissza a fedőlapokat, ügyeljen arra, hogy a kábelek és a többi alkatrészek pontosan a számkúra kijelölt helyen maradjanak.

PL

- Konieczny montaż przez warsztat specjalistyczny.
- Odłączyć przewód masy od akumulatora.
- Zamontować części zgodnie z rysunkiem.
- Ponownie podłączyć akumulator.
- Na powrót osadzić osłony; zadbać aby wiązka kablowa i inne części były właściwie i dokładnie ułożone.

GR

- Να τοποθετεί από συνεργείο.
- Αποσυνδέστε το καλώδιο γείωσης από τη μπαταρία.
- Τοποθέτηση των μερών σύμφωνα με τις Εικόνες.
- Συνδέστε πάλι τη μπαταρία.
- Τοποθετήστε πάλι το κάλυμμα· προσοχή, η πλεξούδα καλωδίων και άλλα μέρη να είναι τοποθετημένα ακριβώς και σύμφωνα με τους κανονισμούς.

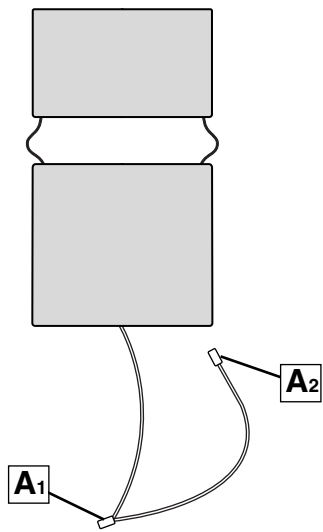
A

2x

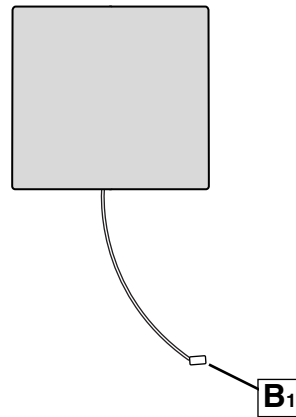
B

2x

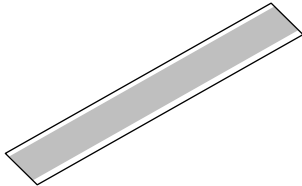
C

1x

D

1x

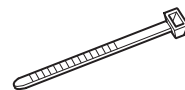
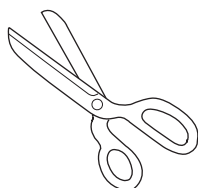
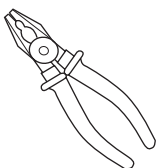

| | GB | D | E | F | I | P | NL | DK |
|----|--------|---------|----------|--------|-----------|----------|--------|--------|
| L | Blue | Blau | Azul | Bleu | Blu | Azul | Blauw | Blå |
| B | Black | Schwarz | Negro | Noir | Nero | Preto | Zwart | Sort |
| BR | Brown | Braun | Marrón | Marron | Marrone | Castanho | Bruin | Brun |
| G | Green | Grün | Verde | Vert | Verde | Verde | Groen | Grøn |
| GR | Grey | Grau | Gris | Gris | Grigio | Cinzento | Grijs | Grå |
| O | Orange | Orange | Naranja | Orange | Arancione | Laranja | Oranje | Orange |
| P | Pink | Rosa | Rosa | Rose | Rosa | Rosa | Rosé | Rosa |
| R | Red | Rot | Rojo | Rouge | Rosso | Vermelho | Rood | Rød |
| W | White | Weiβ | Blanco | Blanc | Bianco | Branco | Wit | Hvid |
| Y | Yellow | Gelb | Amarillo | Jaune | Giallo | Amarelo | Geel | Gul |
| V | Violet | Violett | Violeta | Violet | Viola | Violeta | Violet | Violet |

| | N | S | SF | CZ | H | PL | GR |
|----|-------------|-------------|-------------|----------------|-------------------|-----------------|----------------|
| L | Blå | Blå | Sininen | Modrá | Kék | Niebieska | Μπλε |
| B | Sort | Svart | Musta | Černá | Fekete | Czarna | Μαύρο |
| BR | Brun | Brun | Ruskea | Hnědá | Barna | Brazowa | Καφέ |
| G | Grønn | Grøn | Vihreä | Zelená | Zöld | Zielona | Πράσινο |
| GR | Grå | Grå | Harmaa | Šedá | Szürke | Szara | Γκρι |
| NO | Naturfarger | Naturfärger | Luonnonväri | Přírodní barva | Természetes színű | Barwy naturalne | Φυσικά χρώματα |
| O | Orange | Orange | Oranssi | Oranžová | Narancs | Pomarańczowa | Πορτοκαλί |
| P | Rosa | Rosa | Rosa | Růžová | Rózsaszín | Różowa | Ροζ |
| R | Rød | Röd | Punainen | Červená | Piros | Czerwona | Κόκκινο |
| W | Hvit | Vit | Valkoinen | Bílá | Fehér | Biała | Λευκό |
| Y | Gul | Gul | Keltainen | Žlutá | Sárga | Żółta | Κίτρινο |
| V | Fiolett | Violett | Violetti | Fialová | Ibolyakék | Fioletowa | Μοβ |

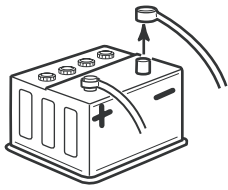

≥ 90"

Airbag

1

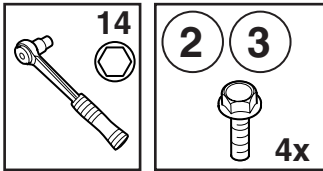

L + R

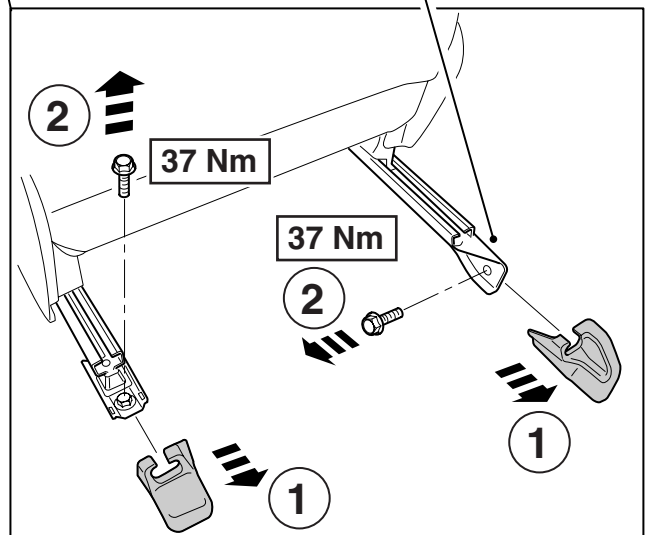
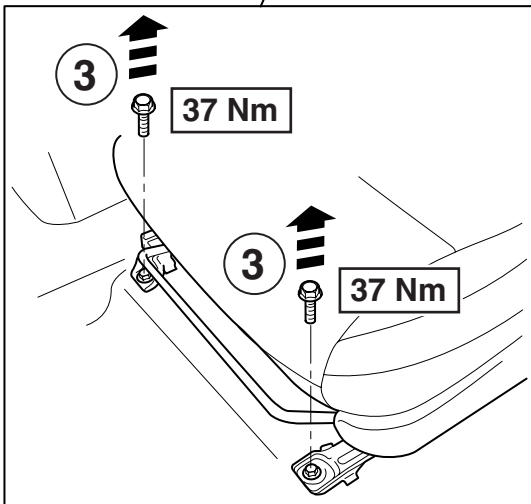
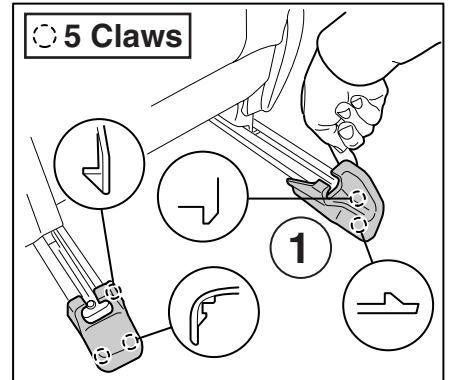
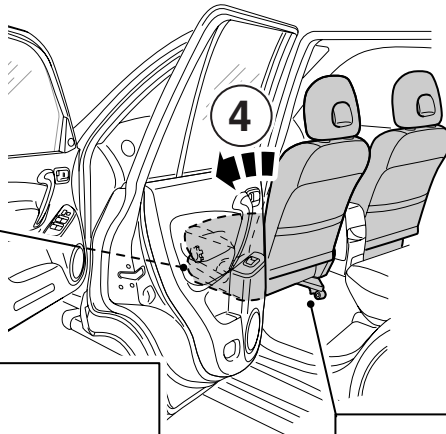

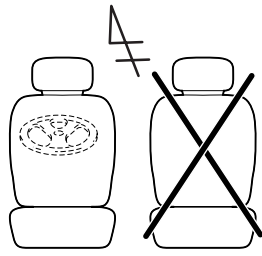

AIM000 103-0

2

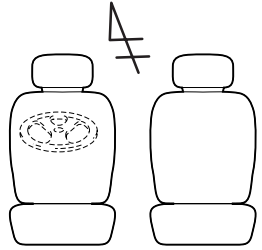

 **4-7**



 **8** 

3

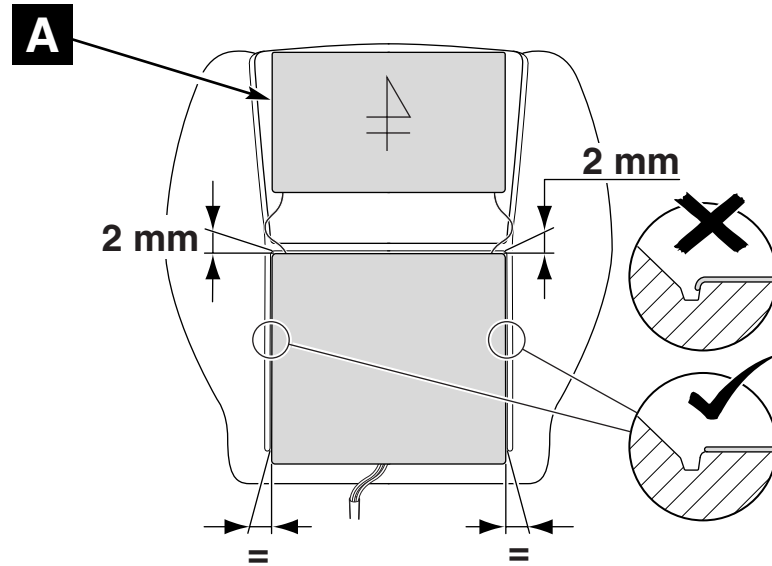
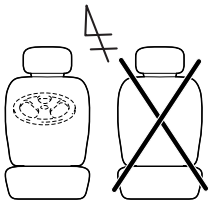

4

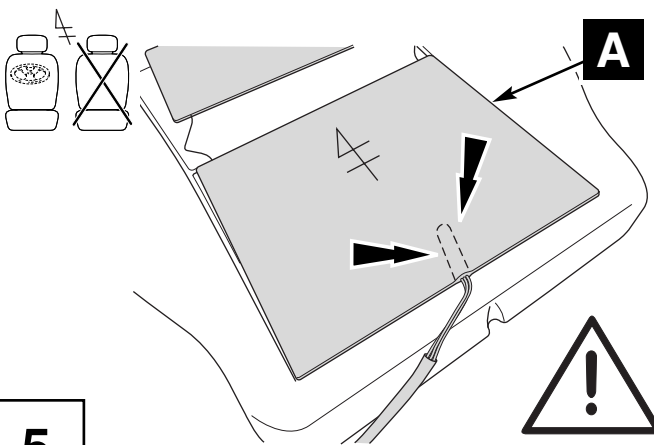

5

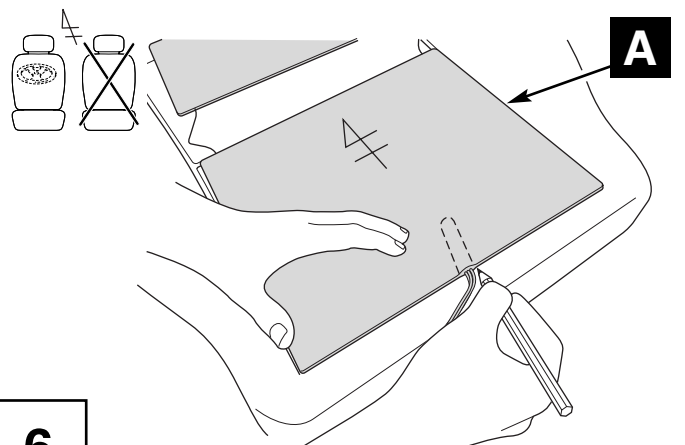

6

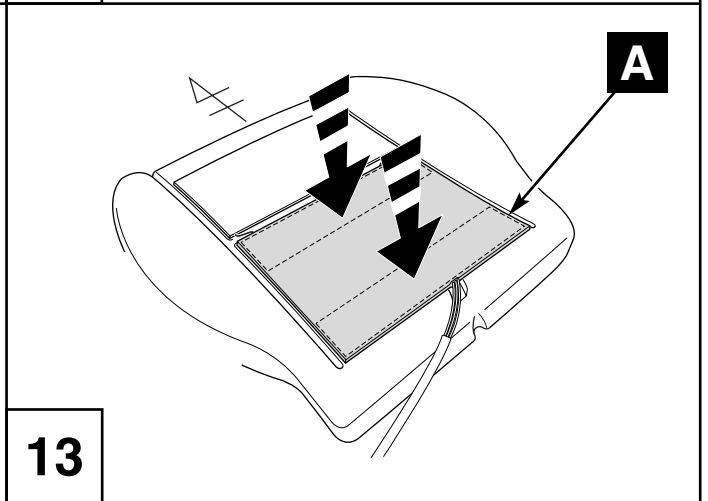
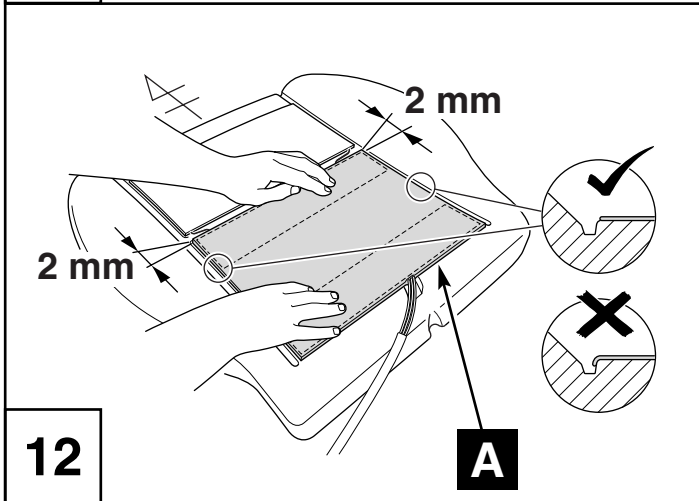
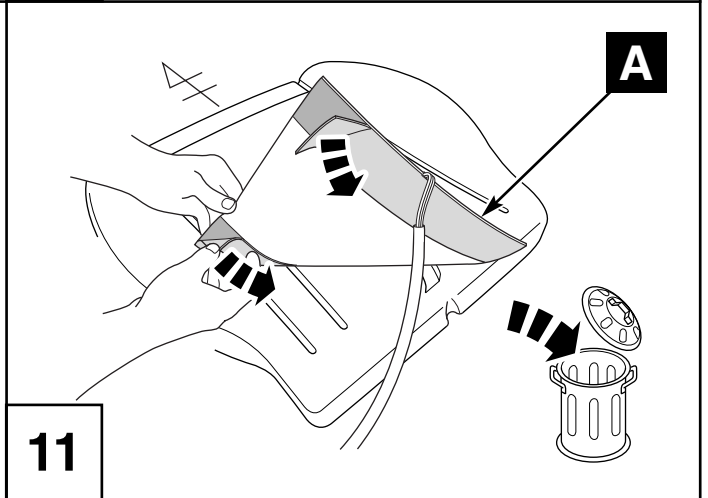
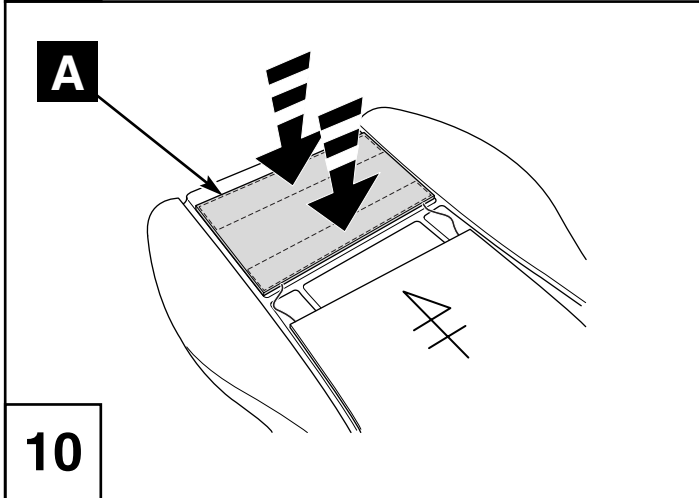
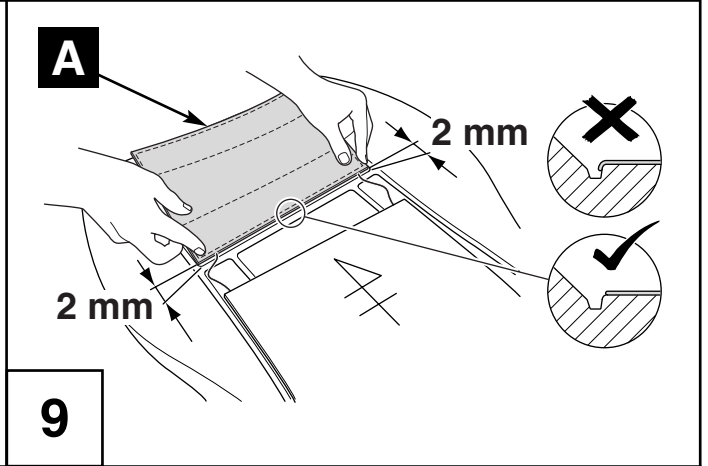
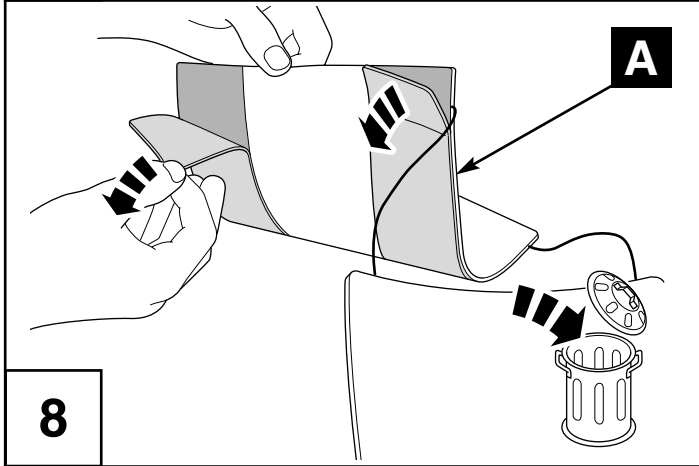
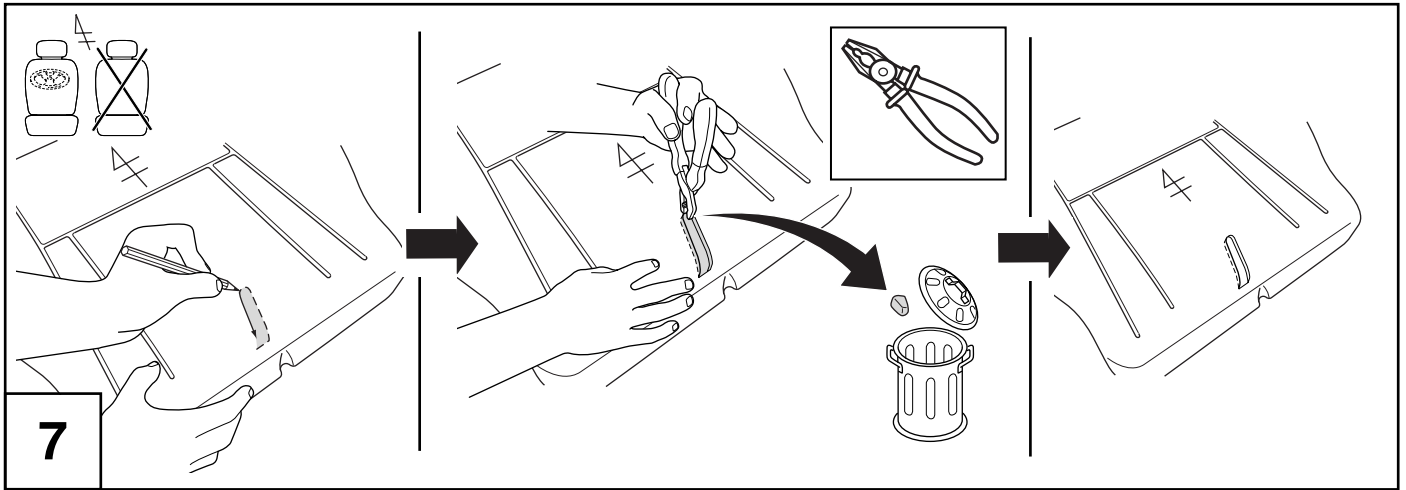

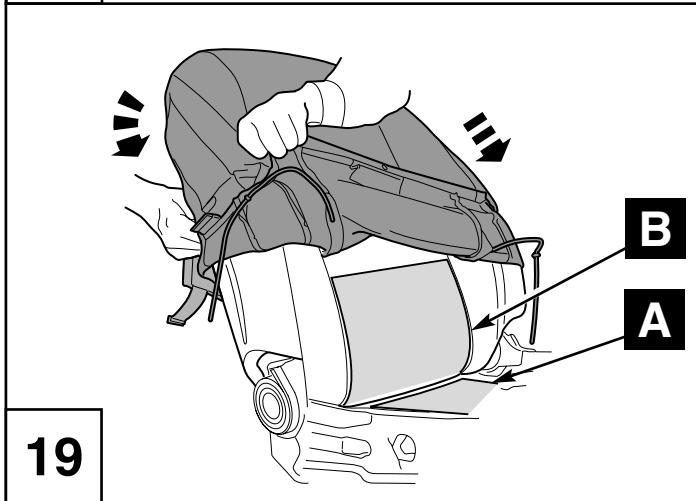
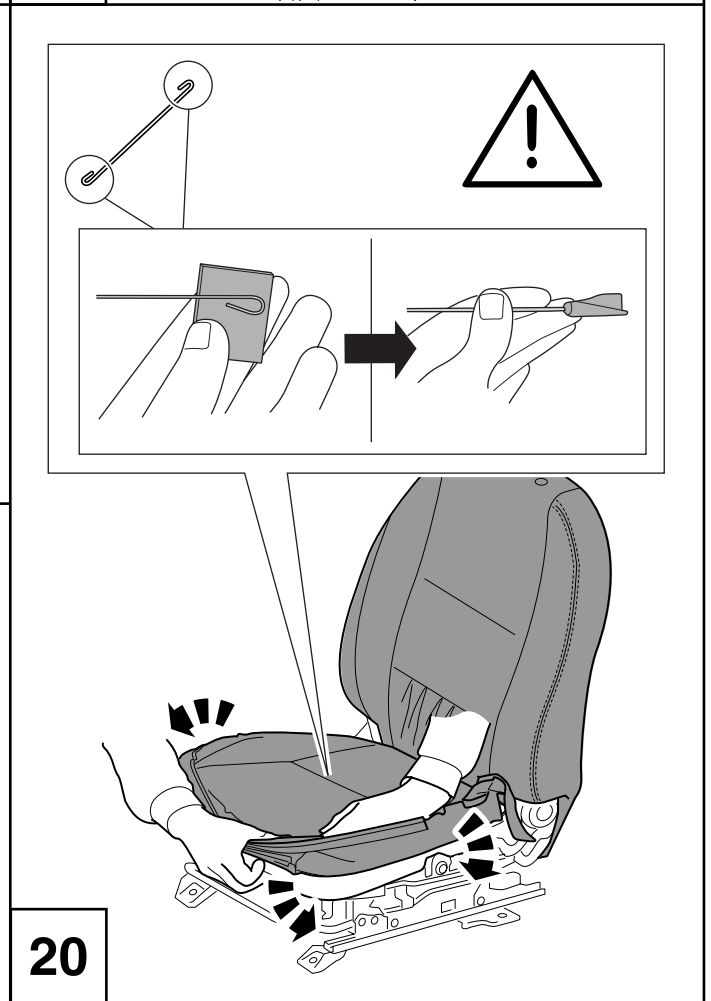
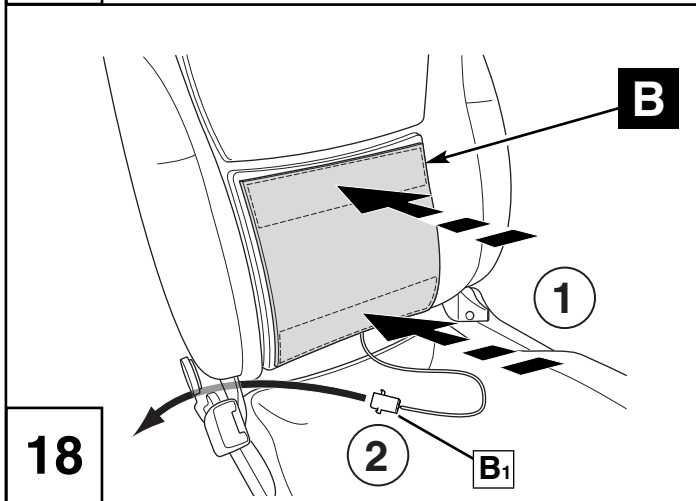
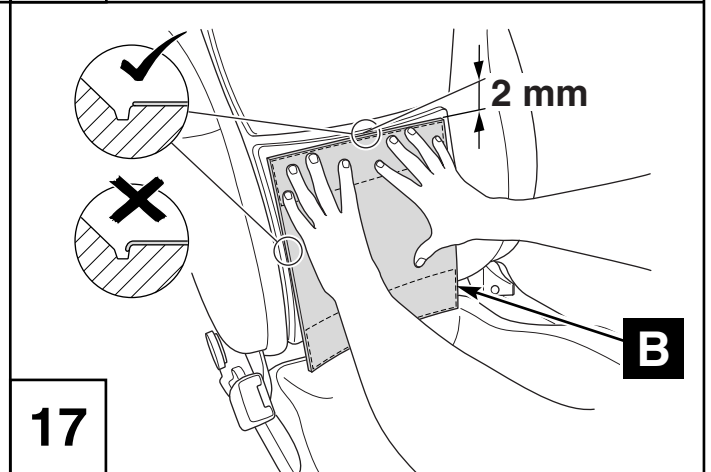
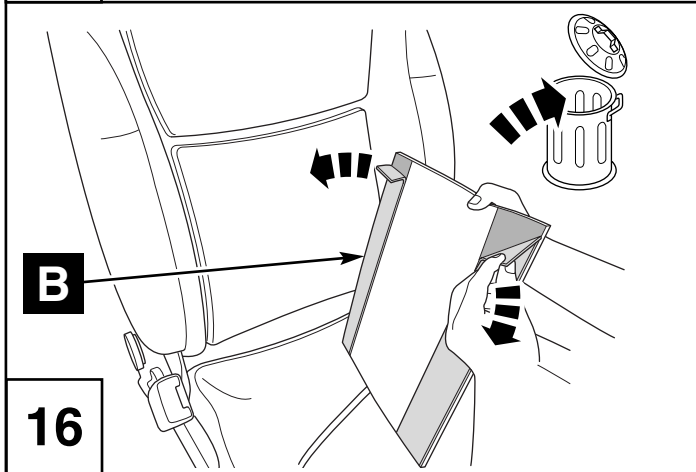
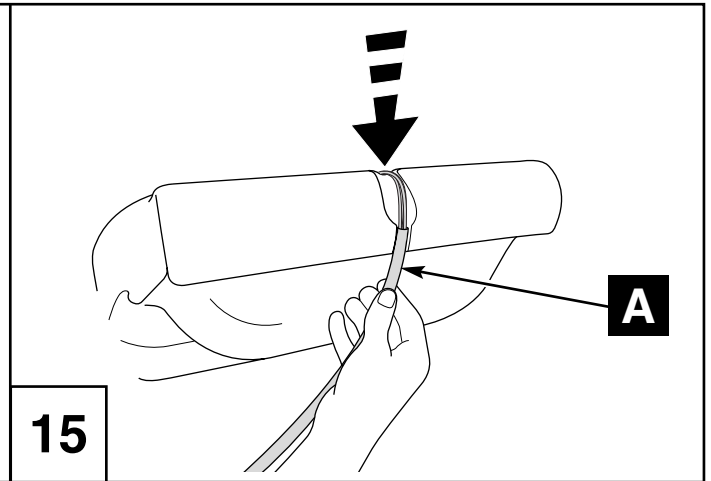
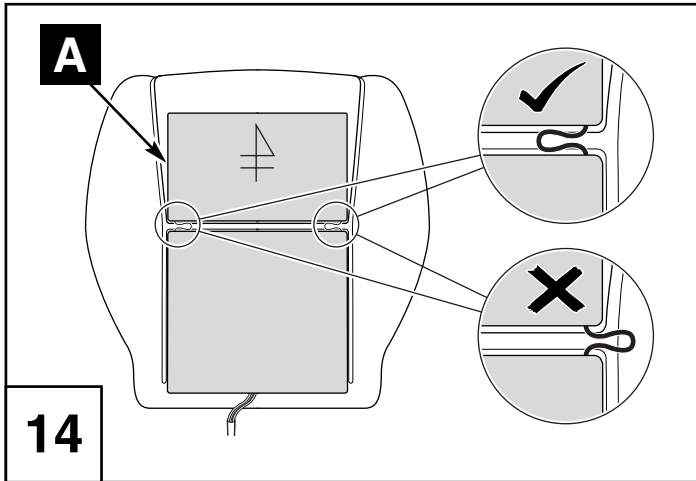

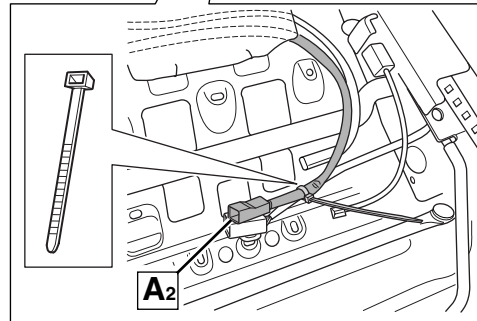
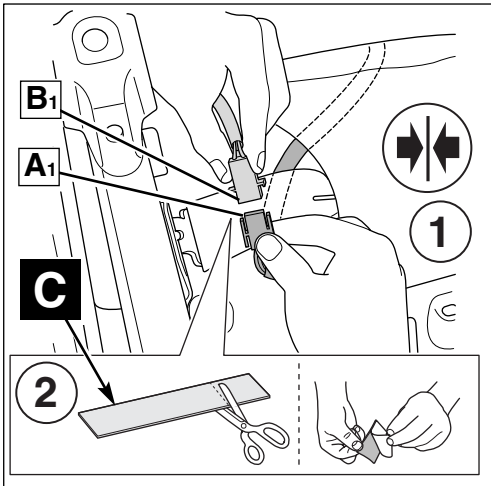
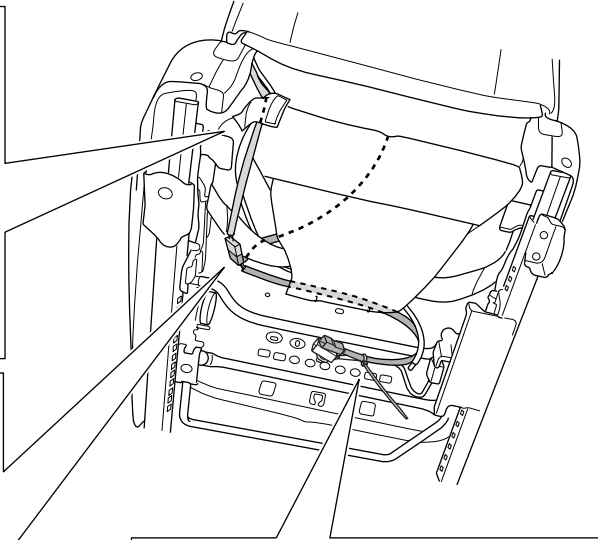
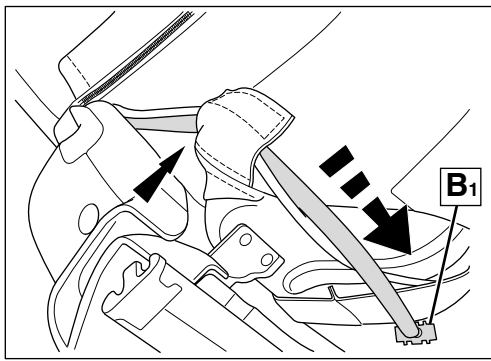

21

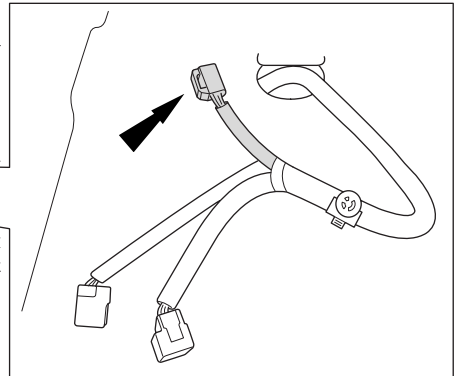
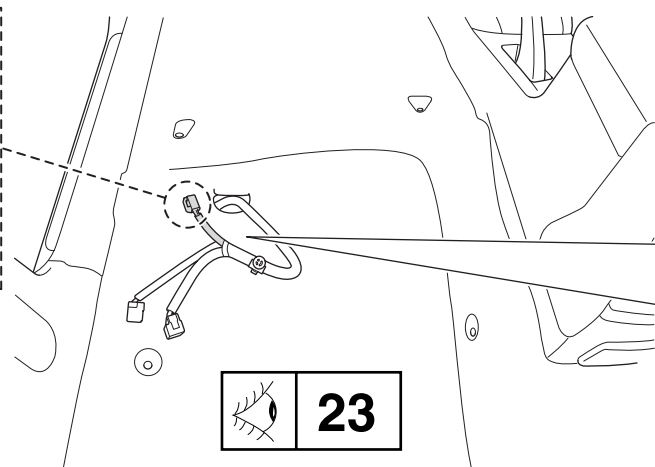
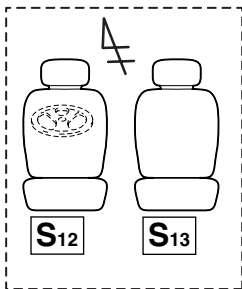

22



23

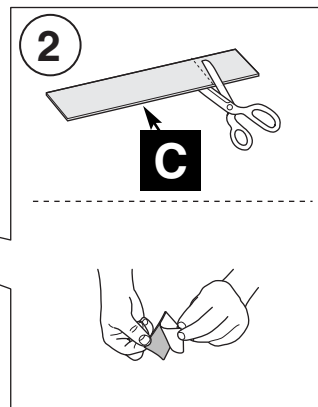
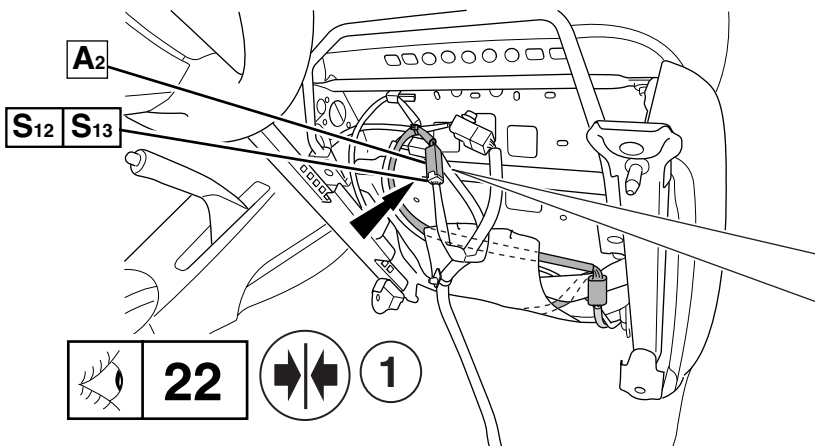

23

