



**Technical Service
BULLETIN**

February 16, 2006

Title:

**GLOVE BOX LOCK
CYLINDER REPLACEMENT**

Models:

'06 RAV4

BODY
B0004-06

Introduction The following procedures have been developed to assist in the replacement of the glove box lock cylinder. Please use the following procedures when replacing the glove box.

- Applicable Vehicles**
- 2006 model year **RAV4** vehicles.

Warranty Information

OP CODE	DESCRIPTION	TIME	OFP	T1	T2
N/A	Not Applicable to Warranty	-	-	-	-

Repair Procedure

1. Remove the glove box from the vehicle.
 - A. Open the glove box and remove the door stopper from the outside panel by depressing the claw and sliding the stopper off. (Refer to "1" in the illustration.)
 - B. Press in on the glove box as indicated by the arrows to release the stop tabs.
 - C. Pull the glove box toward you releasing it from the two (2) hinge points.

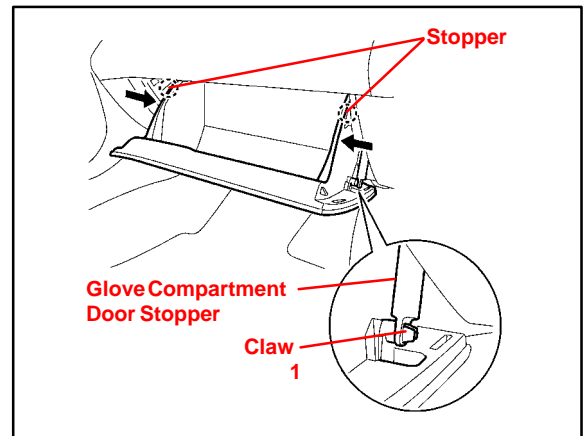

Repair Procedure
(Continued)

2. Remove the latch from the glove box door.
 - A. Remove the 2 Phillips head screws from the inside panel of the glove box door. (Refer to “2” in the illustration.)
 - B. Pull the latch out toward the front to release. (Refer to “3” in the illustration.)

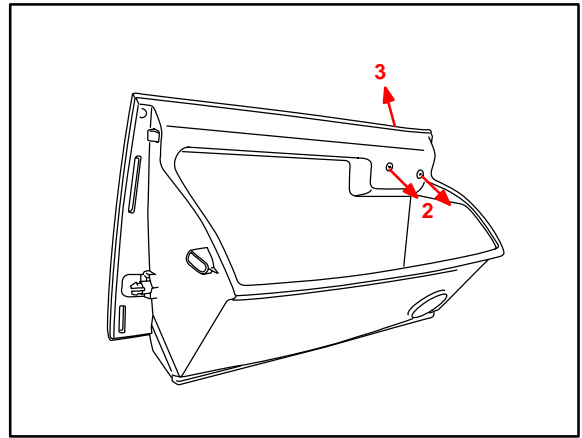

NOTE:
Be careful pulling the latch out. It is connected to the release arms on either end and may be difficult to remove.

3. Remove the lock cylinder from the glove box latch cover.
 - A. Remove the latch cover on the front of the latch assembly.
 - B. Using a flathead screwdriver, pry in the inside of either end of the latch cover and pull the cover off. (Refer to “4” in the illustration.)

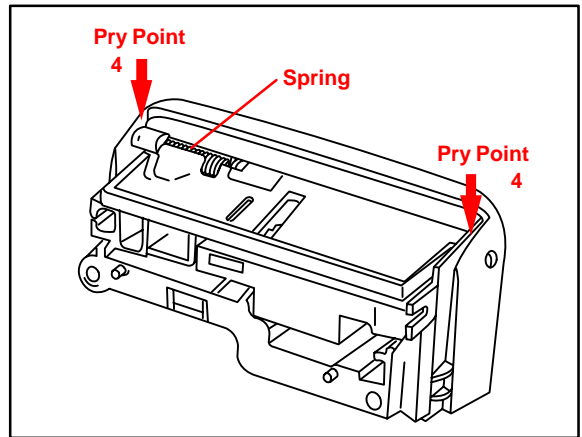

NOTE:
Take care NOT to lose the spring found behind the latch cover. This spring is necessary for reassembly.

- C. Looking at the back of the lock cylinder, push out the three tabs. (Refer to “5” in the illustration.)
 - D. While pushing on the three tabs, slide the gold tab up (refer to “6” in the illustration) and push on the lock cylinder forcing it out. (Refer to “7” in the illustration.)

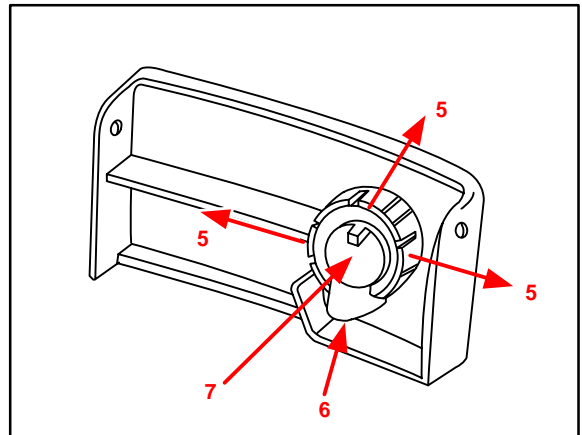

NOTE:
Placing slight pressure on the key cylinder during the release of the tabs will assist in keeping the tabs spread apart.

- E. After the lock assembly has been removed, lightly sand any burrs off the metal tab on the back of the lock cylinder.

Repair Procedure
(Continued)

4. Reinstall the lock cylinder in the new latch assembly cover.
 - A. With the gold tab facing down, insert the lock assembly into the NEW latch assembly cover and press firmly until a “pop” sound is heard.

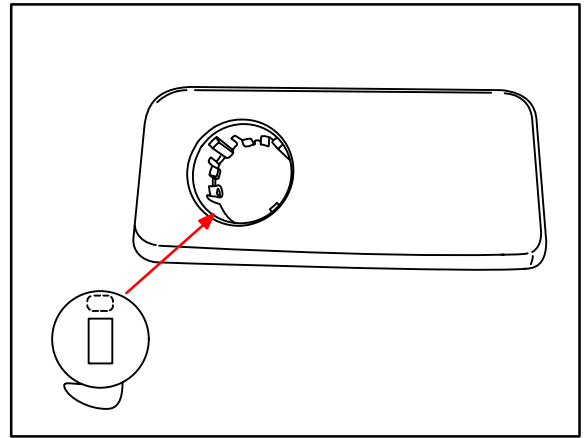

- B. With the latch cover facing down, reinstall the spring in the NEW latch assembly.

NOTE:
Ensure the tip of the spring is pulled to its most downward point when reinstalling the latch cover. If this is NOT done, the latch will NOT operate properly.

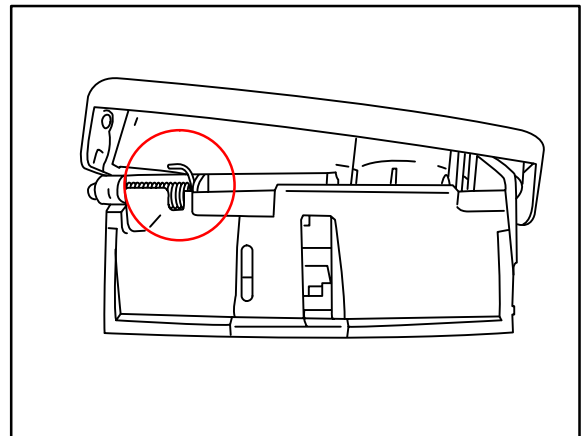

- C. Ensure the slide portion of the back of the latch assembly is fully extended.
 - D. Slide the latch cover over the NEW latch assembly until both pivot pins on the latch assembly are seated in the latch cover.

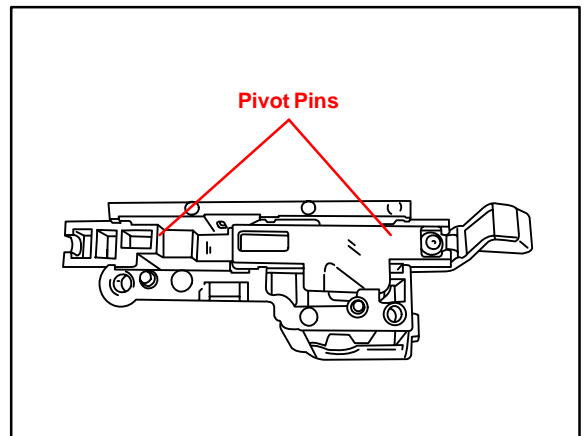

**Repair
Procedure**
(Continued)

5. Reinstall the NEW latch assembly into the glove box.
 - A. Press in on the glove box slide located in the glove box assembly so the ball end of the slide is visible.
 - B. Insert the latch assembly into the glove box and press down until a “pop” sound is heard.
 - C. Reinstall the two screws in the back of the glove box assembly.
6. Reinstall the glove box in the vehicle and reattach the glove box door stopper.
7. Confirm the glove box operates smoothly and the key cylinder is functional.

