



**Technical Service  
BULLETIN**

November 1, 2006

Title:

**COWL PANEL WATER LEAK**

Models:

'06 – '07 RAV4

**TSB**

**REVISÉD**  
**B0021-06**  
**BODY**

**TSB REVISION NOTICE:**

- **March 22, 2007:** 2007 model year has been added to Applicable Vehicles. The illustration in step 8A of the Repair Procedure has been clarified. Steps 5 – 9 and step 13 of the Repair Procedure have been updated. **PLEASE READ ENTIRE TSB.**
- **February 13, 2007:** A note has been added to the Introduction. The VIS' in the Production Change Information table have been updated. Step 8 has been added. The illustration in step 9A has been clarified.

Previous versions of this TSB should be discarded.

**Introduction** Some RAV4 customers may complain of water on the passenger's side floorboard after a heavy rainstorm or when going through a carwash. Water may be traveling underneath the outer cowl panel and entering the passenger compartment through the fresh air inlet of the heater box. The following repair procedure has been made available to correct this concern.

**NOTE:**

This issue addresses water entering into the air inlet. If any other leaks are detected, they need to be fully diagnosed and reported.

**Applicable Vehicles**

- **2006 – 2007** model year **RAV4** vehicles produced **BEFORE** the Production Change Effective VINs shown in this TSB.

**Warranty Information**

OP CODE	DESCRIPTION	TIME	OFP	T1	T2
BD5039	R & R Wiper Arms and Plastic Cowl Cover and Install Seal Plate	0.6	55708-42150	66	55

**Applicable Warranty\*:**

This repair is covered under the Toyota Comprehensive Warranty. This warranty is in effect for 36 months or 36,000 miles, whichever occurs first, from the vehicle's in-service date.

\* Warranty application is limited to correction of a problem based upon a customer's specific complaint.



**Production  
Change  
Information**

PLANT	PRODUCTION CHANGE EFFECTIVE VIN		
	WMI	VDS	VIS
Tahara (11th digit = 5)	JTM	ZD31V#, ZD32V#, ZD33V#, ZD34V#, ZD35V#	75047273
		ZK31V#, ZK32V#, ZK33V#, ZK34V#, ZK35V#	75008494
		BD31V#, BD32V#, BD33V#, BD34V#, BD35V#	75072589
		BK31V#, BK32V#, BK33V#, BK34V#, BK35V#	75019915
Toyota Industries (11th digit = 6)		ZD31V#, ZD32V#, ZD33V#	76030442
		ZK31V#, ZK32V#, ZK33V#	76004749
		BD31V#, BD32V#, BD33V#	76031846
		BK31V#, BK32V#, BK33V#	76014242

**Parts  
Information**

PREVIOUS PART NUMBER	CURRENT PART NUMBER	PART NAME	QTY
N/A	53244-42040	Plate, Seal Set	1

**Required  
Tools &  
Material**

TOOLS & MATERIAL	QUANTITY
3M General Purpose Adhesive Cleaner or equivalent	As Needed

**Repair  
Procedure**

1. Disconnect the cable from the negative (-) battery terminal.

**CAUTION:**

Wait at **LEAST 90 seconds** after disconnecting the cable from the negative (-) battery terminal to prevent airbag and seat belt pretensioner activation.

2. Remove the front wiper arm head caps.
3. Remove the front wiper arm and blade assembly LH by removing the nut.

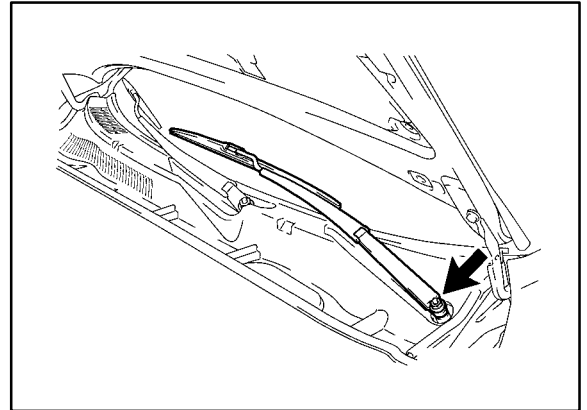

4. Remove the front wiper arm and blade assembly RH by removing the nut.

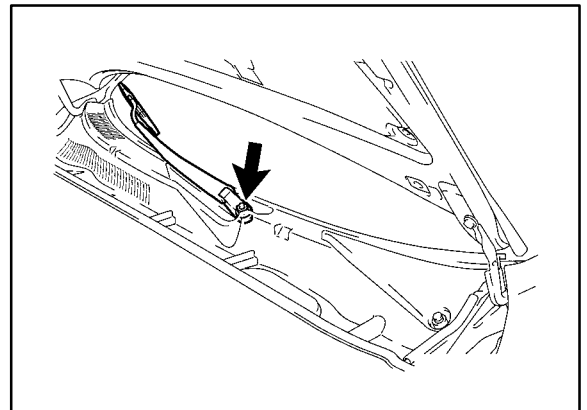

5. Remove the front fender to cowl side seal LH by detaching the claw-type retainer.

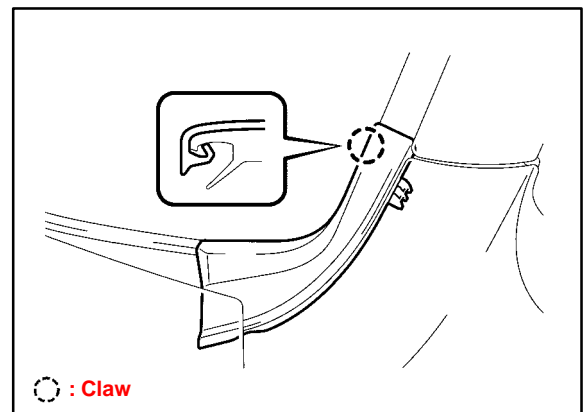

**Repair  
Procedure**  
(Continued)

6. Remove the front fender to cowl side seal RH by detaching the claw-type retainer.

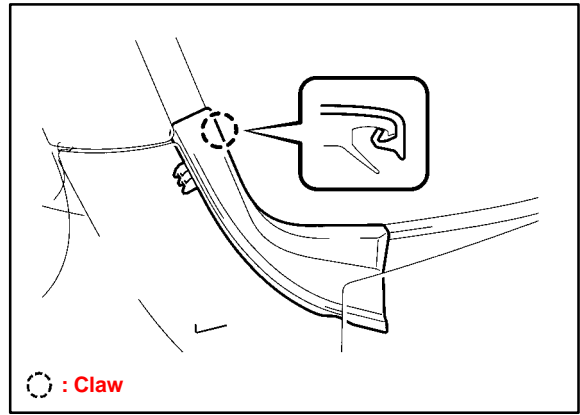

7. Remove the cowl top ventilator louver.  
A. Remove the 2 clips.  
B. Detach the 12 claw-type retainers and remove the louver.

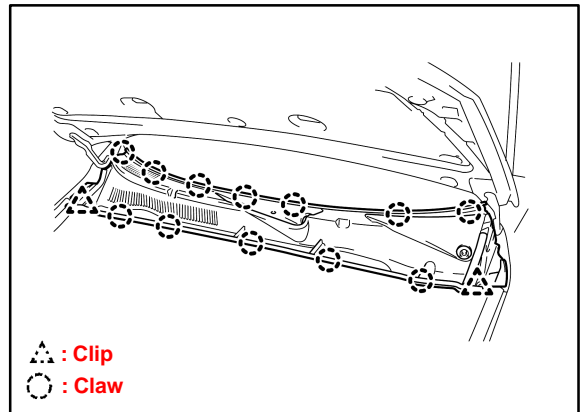

8. Remove any additional factory installed foam, if present, from the areas described below.  
A. Inspect the base of the windshield for foam that is positioned 137 mm (5.5 in.) away from the upper fender bolt on the passenger's side (refer to the illustration).

**Old Foam Dimensions:**

**Length: 275 mm (10.8 in.)**

**Width: 12 mm (0.5 in.)**

**Thickness: 12 mm (0.5 in.)**

- B. Locate and remove the OLD foam on the underside of the cowl top ventilator louver.

**Old Foam Dimensions:**

**Length: 325 mm (12.8 in.)**

**Width: 12 mm (0.5 in.)**

**Thickness: 25 mm (1.0 in.)**

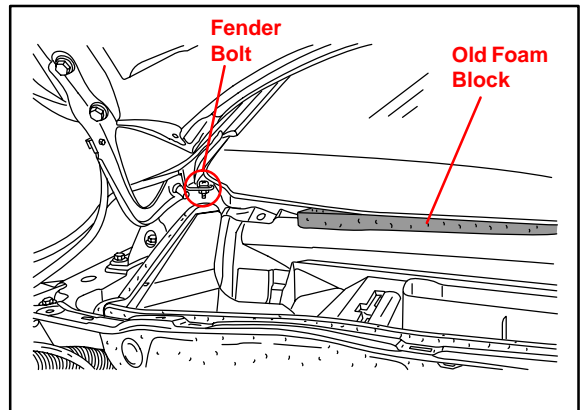

**Repair  
Procedure**  
(Continued)

- C. Clean the sheet metal under the windshield with 3M General Purpose Adhesive Cleaner (P/N 08984) or equivalent.

**NOTE:**

**ONLY use paper towels when cleaning the foam residue from the sheet metal.**

9. Install the NEW seal plate (foam block) on the metal cowl panel as described below.

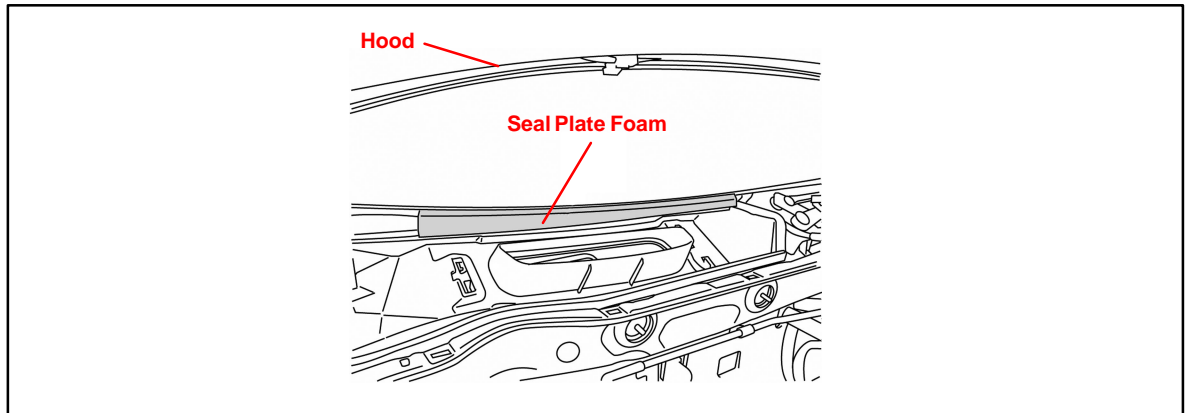

- A. Attach the seal plate (foam block) so that the left end is 30 mm (1.18 in.) from the cut line (point A) on the sheet metal below the windshield and then move toward the center of the windshield.

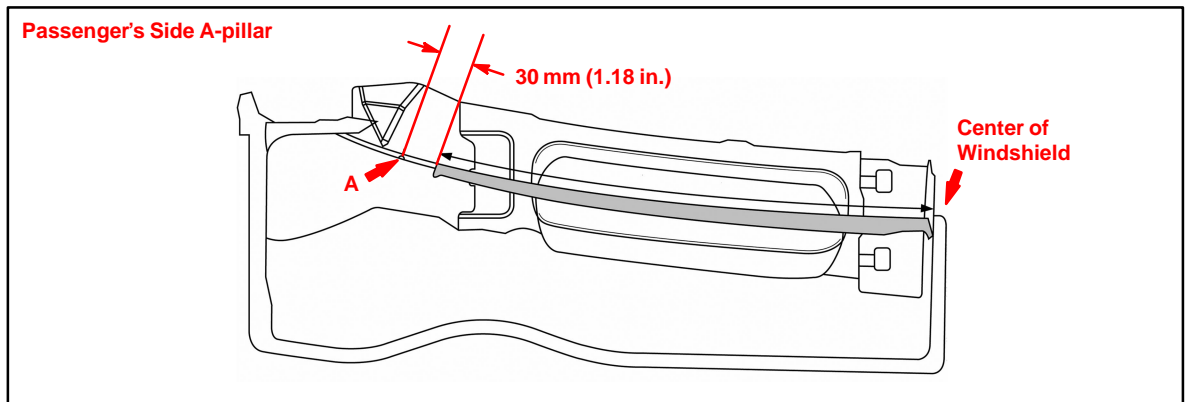

**Repair Procedure**  
(Continued)

- B. Make sure the seal plate (foam block) is fully pressed against the sheet metal under the base of the windshield.

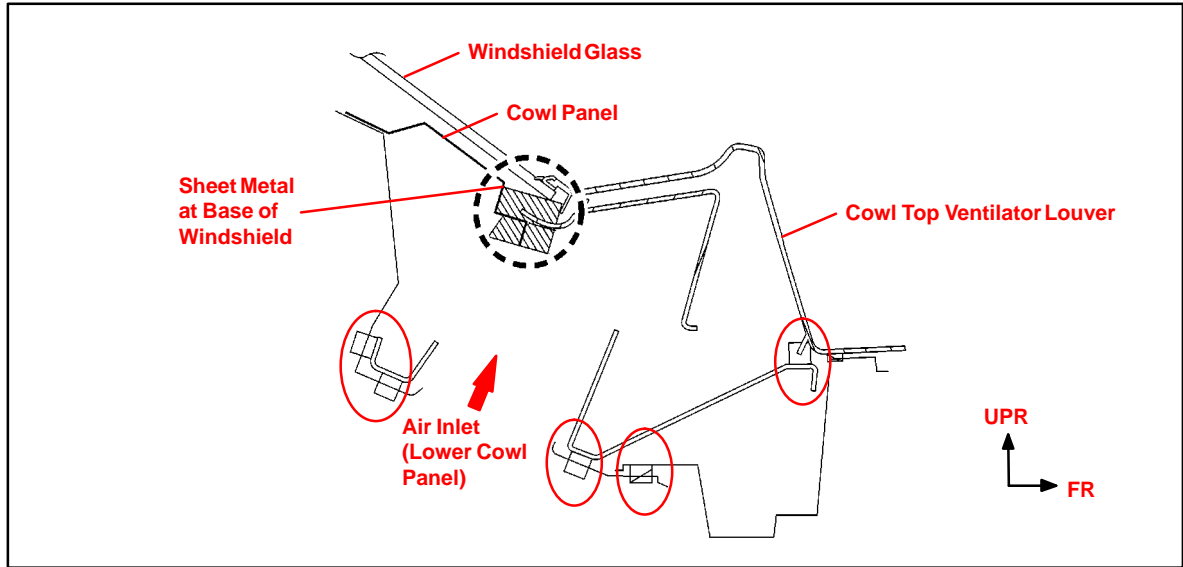

**NOTE:**  
Confirm that the lower cowl panel is properly installed and the seals (circled in red above) are NOT damaged or deformed.

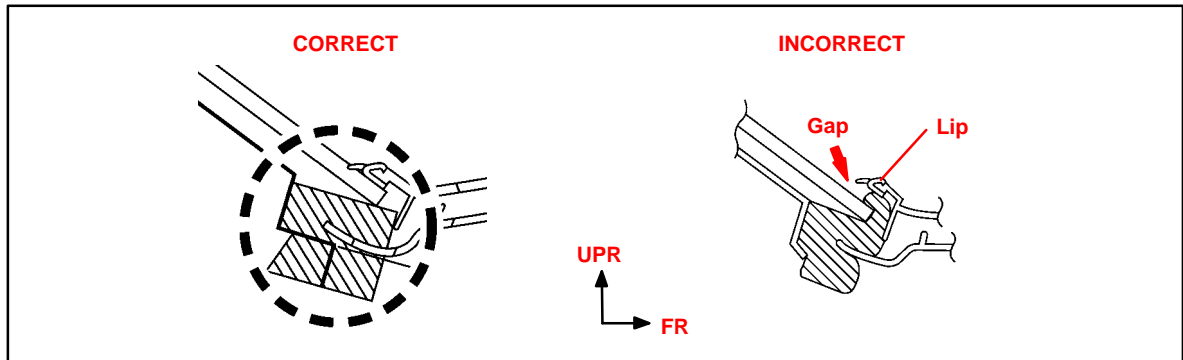

**NOTE:**  
Do NOT leave a gap between the lip and windshield glass.

- 10. Install the cowl top ventilator louver.
  - A. Attach the 12 claws to install the louver.
  - B. Install the 2 clips.

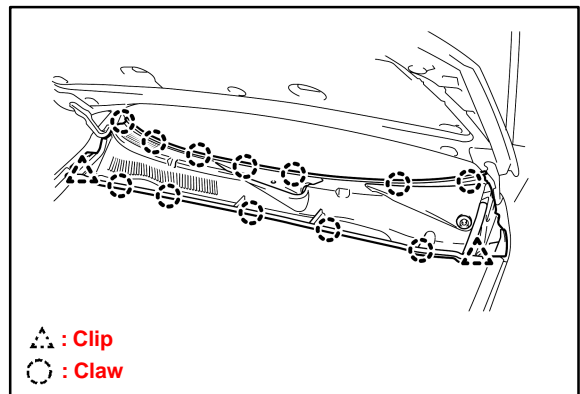

**Repair Procedure**  
(Continued)

- 11. Install the front fender to cowl side seal LH by attaching the claw.

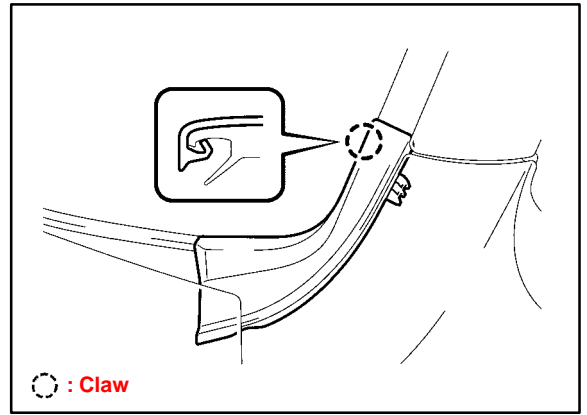

- 12. Install the front fender to cowl side seal RH by attaching the claw.

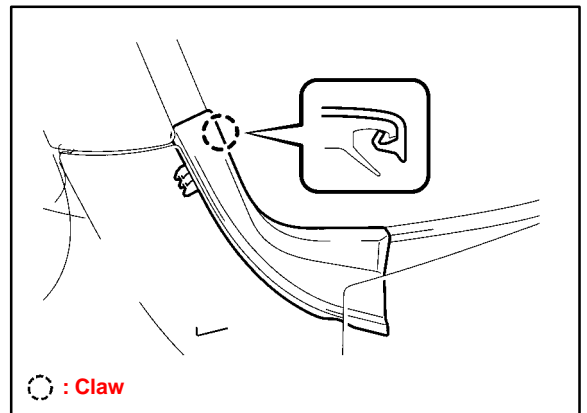

- 13. Install the front wiper arm and blade assembly RH.
  - A. Clean the wiper arm and pivot serration with a wire brush.

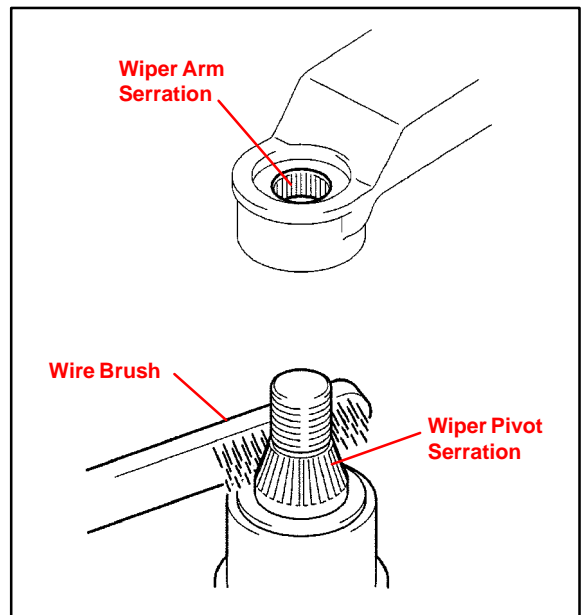

**Repair Procedure**  
(Continued)

- B. Install the arm and blade with the nut. Make sure that the arm and blade come to the position shown in the illustration.

**Torque: 21 N•m**  
(214 kgf•cm, 23 ft•lbf)

**HINT:**

**Hold down the arm hinge while tightening the nut.**

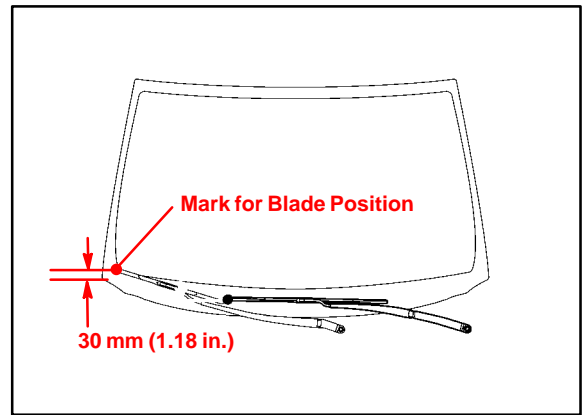

14. Install the front wiper arm and blade assembly LH.

- A. Clean the wiper arm and pivot serration with a wire brush.

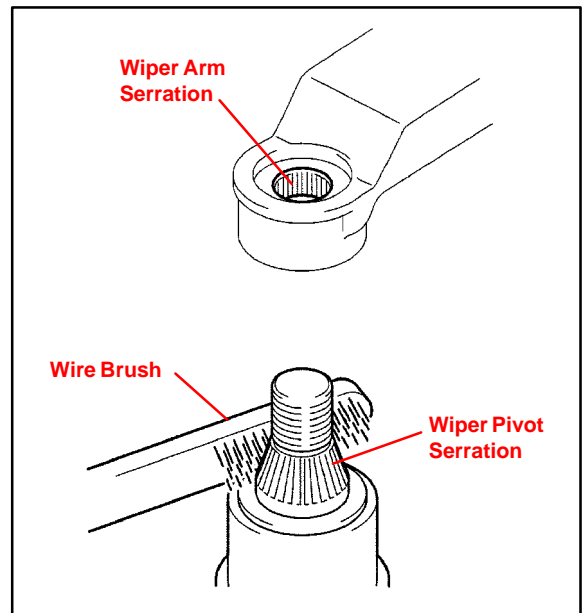

- B. Install the arm and blade with the nut. Make sure that the arm and blade comes to the position shown in the illustration.

**Torque: 21 N•m**  
(214 kgf•cm, 23 ft•lbf)

**HINT:**

**Hold down the arm hinge with your hand while tightening the nut.**

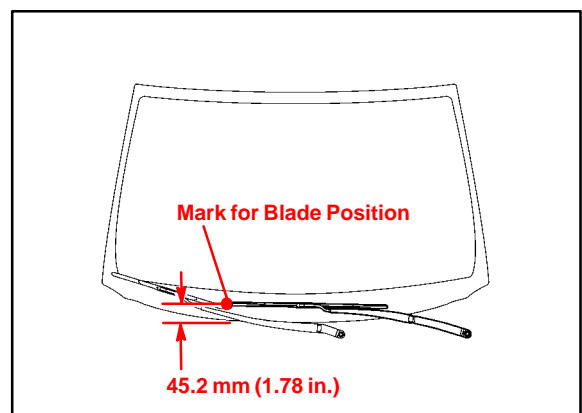

- C. Operate the front wipers while spraying water or washer fluid on the windshield. Ensure that there is NO interference between the blades and A-pillar.



**Repair  
Procedure**  
(Continued)

15. Install the front wiper arm head caps.
16. Connect the cable to the negative (-) battery terminal.
17. Confirm that the issue has been resolved by water testing.