



TOYOTA

Service Bulletin

Section : Pre Delivery

Ref. No. : PD-5032

Date : Oct.,2005

Page : 1 of 6

Area Application : USA, Canada, Europe, General, G.C.C. Countries, Australia

Model Name : TOYOTA RAV4

Model Code : ACA30, ACA33, ACA38, GSA33, GSA38, ALA30

Subject : PDS (Pre-Delivery Service) Information for TOYOTA RAV4

This is to inform you of the following PDS items for TOYOTA RAV4:

CONTENTS

No.	Subject	Page
1	SHORT PIN INSTALLATION DURING PDS	2
2	ACTIVATING PROCEDURE OF TIRE PRESSURE WARNING VALVE & TRANSMITTER (USA/Europe models)	2
3	REMOVAL OF FRONT EMERGENCY TOWING EYELETS AND INSTALLATION OF TOWING EYELET HOLE COVERS	5
4	FRONT LICENSE PLATE INSTALLATION (USA/Canada models)	6
*	SHIFT LOCK RELEASE BUTTON COVER INSTALLATION (USA/Canada models)	-
*	INSTALLATION OF RUBBER BODY PLUG	-

*: Not covered.

Part No. Information :

New Part No.	New Part Name	Qty
NA	NA	-

Production Effective :

VIN	Production Date
NA	November 2005

1. SHORT PIN INSTALLATION DURING PDS

The Short Pin has been removed on the TOYOTA RAV4 at assembly plant to reduce parasitic current draw in transit and storage.

The removed Short Pin is stored in the blank space of the fuse block in the engine compartment. The Short Pin must be reinstalled to the original location during PDS (Pre-Delivery Service) in dealership as shown below.

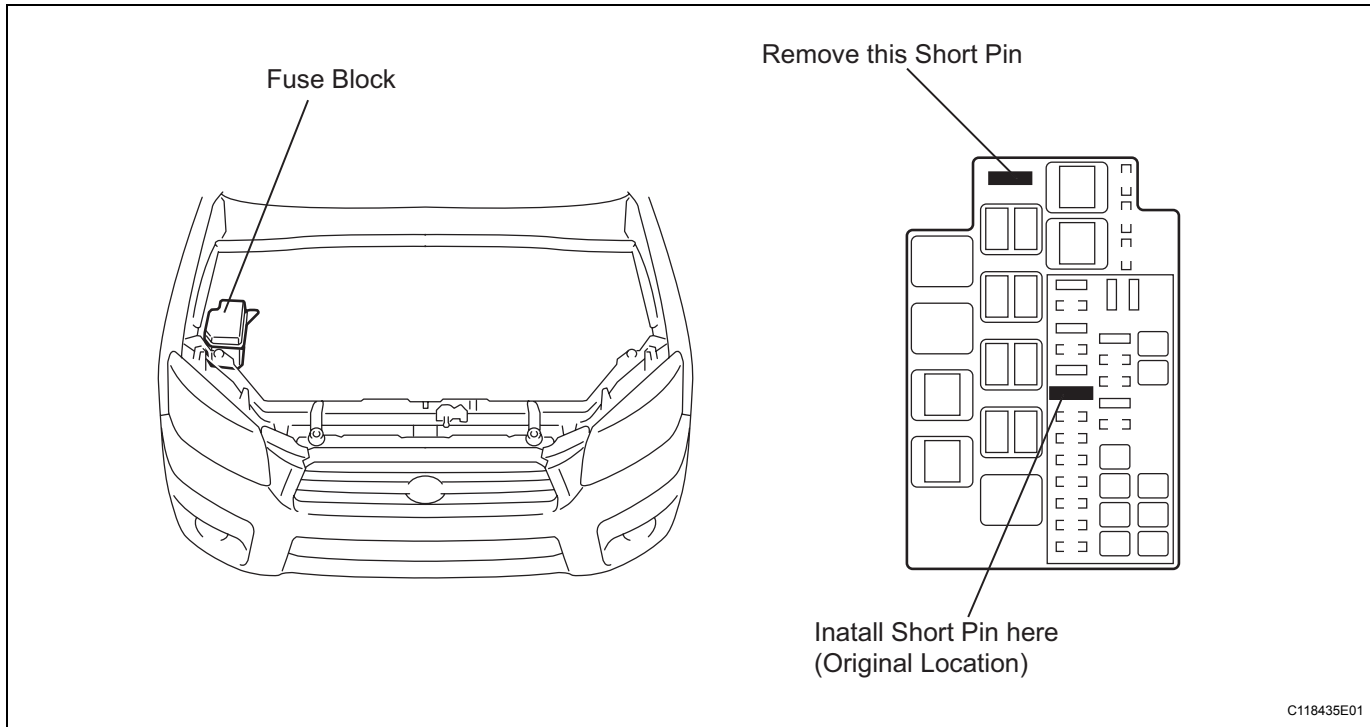

NOTICE:

While the vehicle is stored at the dealership, please disconnect the negative battery terminal to prevent parasitic current draw from draining the battery.

2. ACTIVATING PROCEDURE OF TIRE PRESSURE WARNING VALVE & TRANSMITTER

The tire pressure warning valve & transmitter is built in each tire valve, and measured tire inflation pressure data is sent to the tire pressure warning antenna by electric wave and then to the receiver. However, the electric wave is stopped at assembly plant, because the strength of the electric wave emitting from the tire pressure warning valve & transmitter does not comply with the Japan Wireless Telegraphy Act.

Please activate the tire pressure warning valve & transmitter to operate the tire pressure warning system during PDS (Pre-Delivery Service) at the dealership according to the procedure outlined below.

HINT:

The tire pressure warning light is blinking, until the all tire pressure warning valve & transmitter are activated.

The following Diagnostic Trouble Codes (DTC) are stored in the system, but they are cleared automatically when the tire pressure warning valve & transmitter is activated.

DTC No. *1	DTC No. *2	Meaning of DTC
11	C2111	Transmitter ID1 operation stop. (sleep mode)
12	C2112	Transmitter ID2 operation stop. (sleep mode)
13	C2113	Transmitter ID3 operation stop. (sleep mode)
14	C2114	Transmitter ID4 operation stop. (sleep mode)

DTC No. *1	DTC No. *2	Meaning of DTC
15 *3	C2115	Transmitter ID5 operation stop. (sleep mode)

*1: DTC No. indicated by blinking of the tire pressure warning light.

*2: DTC No. indicated on the intelligent tester.

*3: USA model

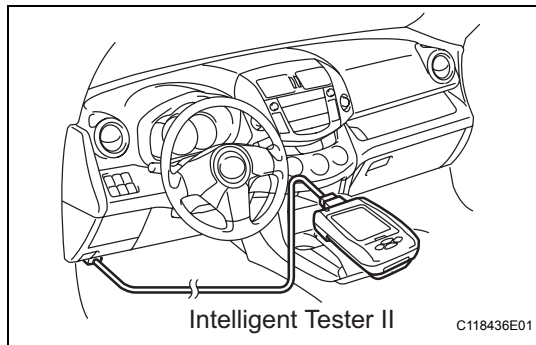

1. Activation Procedure

(a) Connect the intelligent tester.

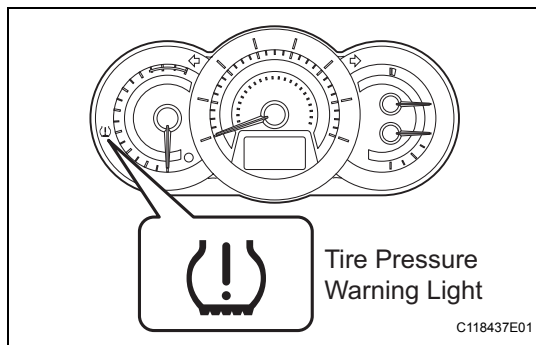

(b) Switch to "IG-ON" position, and check that the tire pressure warning light blinks.

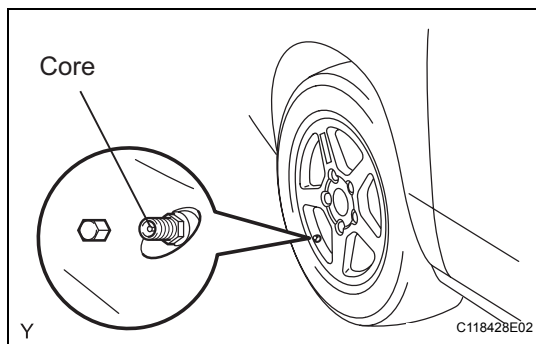

(c) Remove the cap of the tire valve, and press the valve core to quickly decrease tire pressure by 6 psi (40 kPa) or more within 30 seconds for each tire one by one (including the spare tire*) in order to activate the tire pressure warning valve & transmitter.

If tire pressure is not quickly decreased by 6 psi (40 kPa) or more within 30 seconds, the tire pressure warning valve & transmitter will not be activated.

*: USA model

(d) Using the intelligent tester, check that DTCs for "tire pressure warning valve & transmitter stop". If DTCs for "tire pressure warning valve & transmitter stop" are not output, proceed to step (g).

If DTCs for "tire pressure warning valve & transmitter stop" are output, proceed to step (e). If a DTC other than "tire pressure warning valve & transmitter stop" DTCs is also stored, refer to the Repair Manual.

- (e) Decrease (or increase) tire pressure by 6 psi (40kPa) or more within 30 seconds for each tire in order to activate the tire pressure warning valve & transmitter.

Check if the tire pressure displayed on the intelligent tester changes, and DTCs for "tire pressure warning valve & transmitter stop" are not output.

If the tire pressure displayed on the intelligent tester has changed (decreased or increased), and DTCs for "tire pressure warning valve & transmitter stop" are not output, proceed to step (g).

- (f) Check for DTCs. If DTCs for only "tire pressure warning valve & transmitter stop" are stored, turn all tires (including the spare tire*) by 90 to 270 degrees and wait for several minutes have elapsed, if the sensors have been activated, the DTCs will automatically be cleared.

If a DTC other than "tire pressure warning valve & transmitter stop" DTCs is also stored, refer to Repair Manual.

*: USA model

HINT:

- If the DTCs have still not cleared themselves even after several minutes have elapsed, it is possible that the ID codes of the tire pressure warning valve & transmitters are not the same ones that are registered to the ECU (if a set of wheels have been changed).
- If the ID code of the tire pressure warning valve & transmitter and that of the ECU do not match, register the current ID code of the tire pressure warning valve & transmitters to the ECU.
- If any parts are malfunctioning, refer to the Repair Manual.
- If the above procedures cannot be performed, move the vehicle and check that there is no device that emits electrical interference inside or outside the vehicle.

- (g) Adjust tire pressure to the specified level. Check that the tire pressure warning light is off.

HINT:

- If there is a great difference between the current temperature of the tire and wheel (example: shop temperature) and expected temperature (outdoor temperature), this needs to be considered when adjusting the tire pressure.
- Adjust tire pressure when the tires are cold.

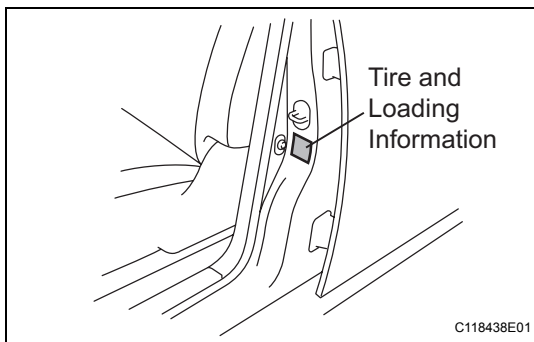

3. REMOVAL OF FRONT EMERGENCY TOWING EYELETS AND INSTALLATION OF TOWING EYELET HOLE COVERS

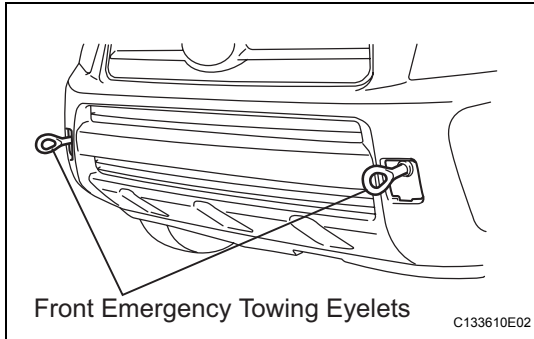

1. Removal and Installation Procedure

- (a) Remove the emergency towing eyelets from the front bumper by turning them counterclockwise.
HINT:
If it is hard to loosen the emergency towing eyelet, use a steel bar.

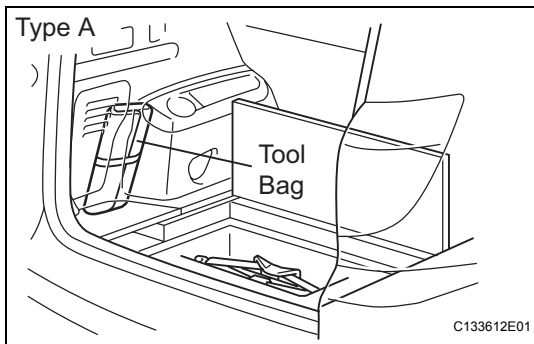

- (b) Put one of two removed emergency towing eyelets in the tool bag stored in the luggage storage box. Dispose the other removed emergency towing eyelet.

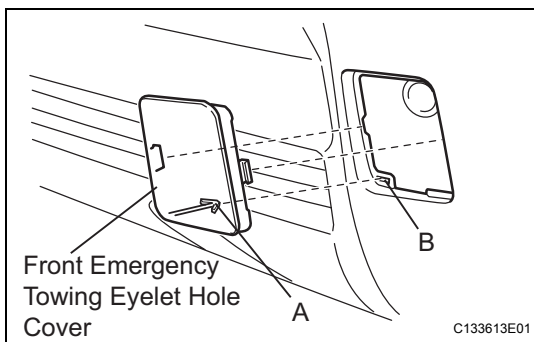
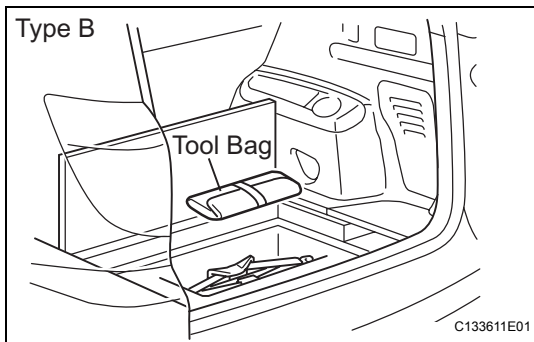

- (c) Install the front emergency towing eyelet hole covers which are stored in the glove box onto the front bumper.
 - (1) Insert the arrow-shaped part (A) of the front emergency towing eyelet hole cover into the hole (B) as illustrated.
 - (2) Install the front emergency towing eyelet cover to the hole of the front bumper.

4. FRONT LICENSE PLATE INSTALLATION

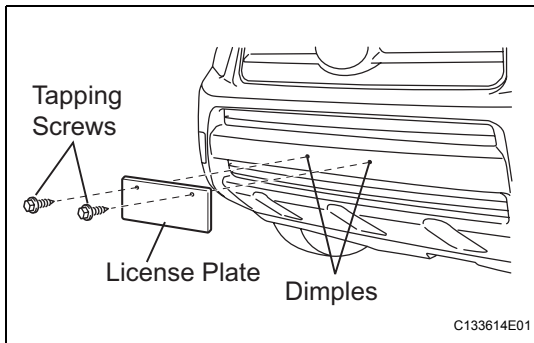

1. Installation Procedure

- (a) Align the installation holes of the front license plate with the dimples of the front bumper.
- (b) Using two self-tapping screws, install the front license plate by directly screwing in the tapping screws onto the dimples.

HINT:

Do not pre-drill holes in the dimples.

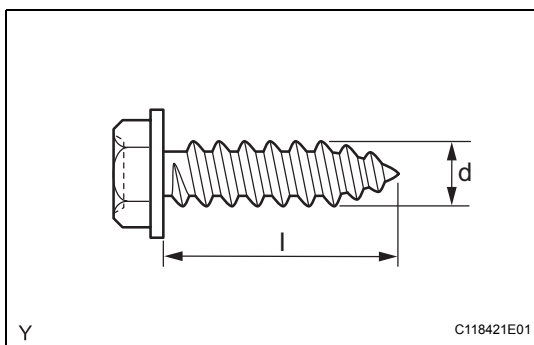

2. Recommend Self-Tapping Screw

- (a) Use the self-tapping screws of a non-corroding type having the following size for installation of the front license plate.

Nominal length (l): 15.0 - 20.0 mm (0.59 - 0.79 in.)

Diameter (d): 6.0 mm (0.24 in.)